

PELLET PROCESSING SYSTEMS FOR THE PLASTICS INDUSTRY

GALA PELLETTIZERS & PELLETTIZING SYSTEMS

© SEPTEMBER 2010 • GALA INDUSTRIES, INC.

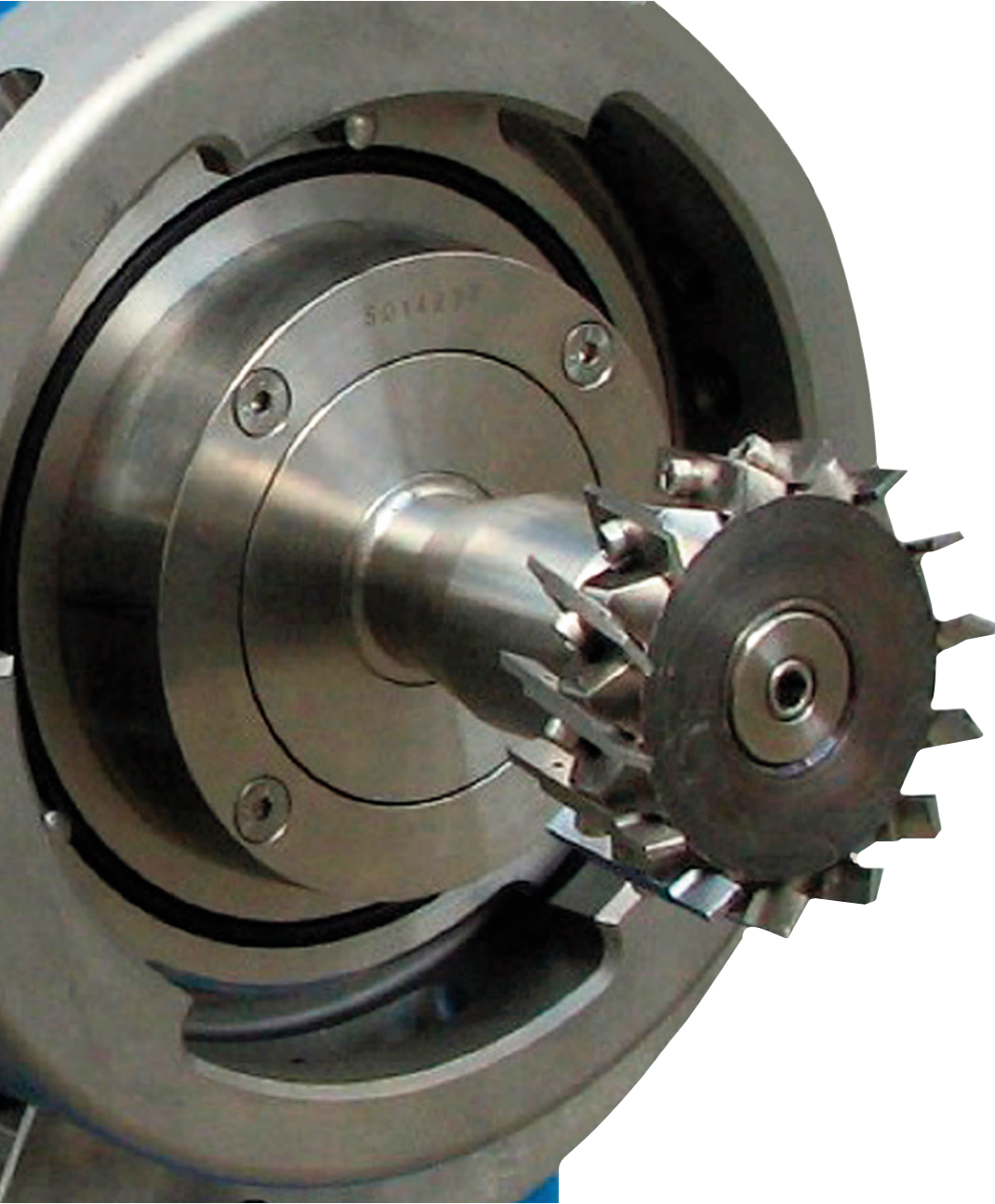

INSIDE THIS BROCHURE:

- About Gala Pelletizers
- Benefits
- Process Flow Schematic
- Pelletizer Rates
- Gala Pelletizer Models
- Gala Pelletizing Systems
- Special Applications
- Pelletizer Components
- Support Information
- Request a Quotation

APPLICATIONS FOR GALA UNDERWATER PELLETTIZERS

- Compounding
- Masterbatch Production
- Virgin Resin Production
- Engineering Resins
- Medical Polymers
- Food Grade Polymers
- Plastics Recycling
- Micropellets
- Hot Melt Adhesives
- Thermoplastic Elastomers
- Wood Polymer Composites
- Research & Development
- And more....

- ✓ Quality
- ✓ Innovation
- ✓ Commitment
- ✓ Service



GALA UNDERWATER PELLETTIZERS

Gala has provided underwater pelletizers for the Plastics Industry since the mid-seventies for pelletizing rates from 2 kg/h to 15.000 kg/h.

Gala Underwater Pelletizing Systems are designed to provide solutions for our Customers' most relevant economic and ecological needs:

- Safe pelletizing process
- Low energy requirements
- Flexible floor arrangement
- Automated start-up, shutdown, and remote operation for operator-independent process
- Increased efficiency and capacity due to less waste
- Smooth, uniform pellets
- Pellet size range flexibility to suit Customer needs
- Horizontal flow through die, reducing polymer degradation

Our process knowledge, experience, and commitment to our Customers remain the foundation of Gala's success.

DESIGN FLEXIBILITY

Gala makes every effort to remain flexible in order to meet the demands of our Customers.

Traditionally, the Gala Underwater Pelletizer rolls into the cutting chamber /upstream system on small rails mounted on the floor. In some situations, the floor must remain clear; therefore, we offer a top mounted (or hanging) pelletizer design.

Budget is often a consideration. We offer pelletizer models which are very simple in design. These robust models do the job efficiently and there are thousands in operation in the field today. Gala's Customer can choose a pelletizer fitted with a special chassis (optional) when more room is needed between pelletizer and upstream equipment, such as a polymer diverter valve.

BENEFITS

Safety

- Automated start-up & shutdown
- Redundant safety interlocks
- Failsafe pelletizer clamping assembly

Environmental

- Clean operation with low noise levels
- Low energy consumption
- Efficient closed loop filtered water system

Profitability

- Minimal start-up waste
- Suitable for various polymers, offering greater flexibility of a single machine
- Minimal floor space
- Uniform pellets in sizes to customer specifications
- Low production costs

*Design flexibility –
to meet our
Customer's needs*

Model A5-PAC12 Pelletizer
with European stand



Model MAP-7
with casters



Model A5-PAC 7 with
special chassis



Model MAP-7 top mounted pelletizer



SPRING LOADED PELLETIZER



Model SLC

Production Rate: 2 kg/h to 3.000 kg/h

The Spring Loaded Cutter (SLC) is a cost efficient solution for pelletizing basic polymers at lower rates.

The SLC pelletizer uses constant spring pressure to adjust the cutter blades to the die plate, reducing the need for operator attention.

The cutter hub is connected to the motor shaft through a telescoping spring sleeve, and the blades are automatically positioned against the die plate using spring force. The blade force can be adjusted per application or product by simply changing springs.

QUICK SPECS

- Cost efficient solution
- Simple to operate
- Low maintenance

MANUALLY ADJUSTABLE PELLETIZER



Model MAP

Production Rate: 2 kg/h to 15.000 kg/h

The Manually Adjustable Pelletizer (MAP) features a manual adjusting wheel to position the blades against the die plate. This simple blade adjustment design provides visual blade wear indication and maximum control of blade position.

The unique design of the axial advance system replaces the need for a bearing housing assembly. The MAP design requires only one long life thrust bearing for accurate adjustments.

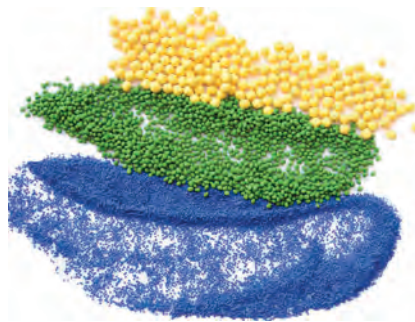

QUICK SPECS

- Simple blade adjustment
- Flexibility of application
- Easy to upgrade to automatic blade adjustment

AUTOMATED ADJUSTMENT PELLETIZER



Model A5-PAC

Production Rate: 2 kg/h to 15.000 kg/h

The hydro-pneumatically adjusted cutter (A5-PAC) and the electronically adjusted cutter (EAC) offer fully automated control of blade adjustment.

The pelletizer models featuring automated adjustment offer fully automated control of blade positioning and monitoring, resulting in maximum blade and die face life.

Monitoring and adjustment processes are programmed in the Gala PLC controlled system.

An optional integrated blade position measuring system is available, providing indication of blade position and alerting the need for a blade change.

QUICK SPECS

- Automated blade advance
- Minimum operator supervision
- Integrated blade positioning measurement system



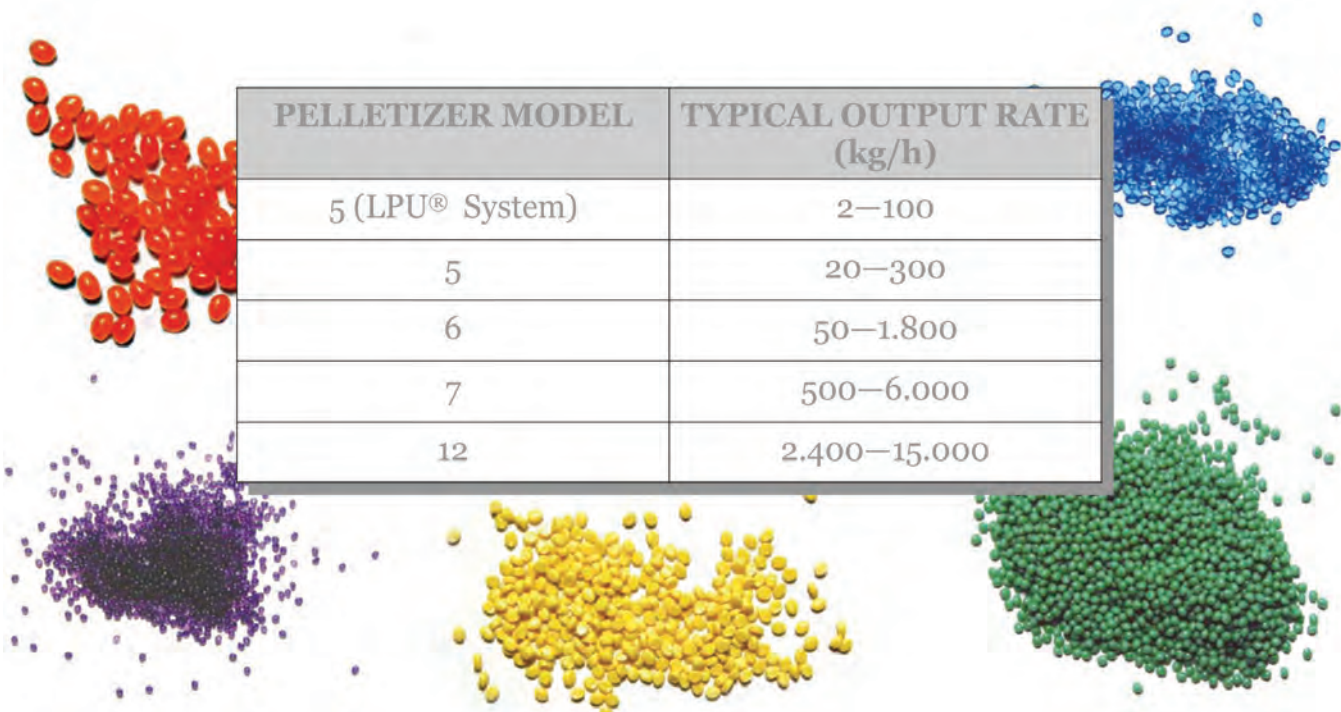

PELLETIZER MODEL	TYPICAL OUTPUT RATE (kg/h)
5 (LPU® System)	2–100
5	20–300
6	50–1.800
7	500–6.000
12	2.400–15.000

PROCESS SCHEMATIC

The process schematic shows the flow of resin through a Gala Underwater Pelletizing System. Material is fed into an extruder or melt pump, which forces the molten polymer through a screen changer and/or polymer diverter, then through the pelletizer die plate. As the polymer emerges from the die, pellets are cut by rotating blades and are solidified by the process water flowing across the die face inside the cutting chamber. The process water transports the pellets to a centrifugal dryer where the water is removed and the dry pellets are discharged. The process water is contained in a closed loop so there is minimal water loss and very little housekeeping involved.

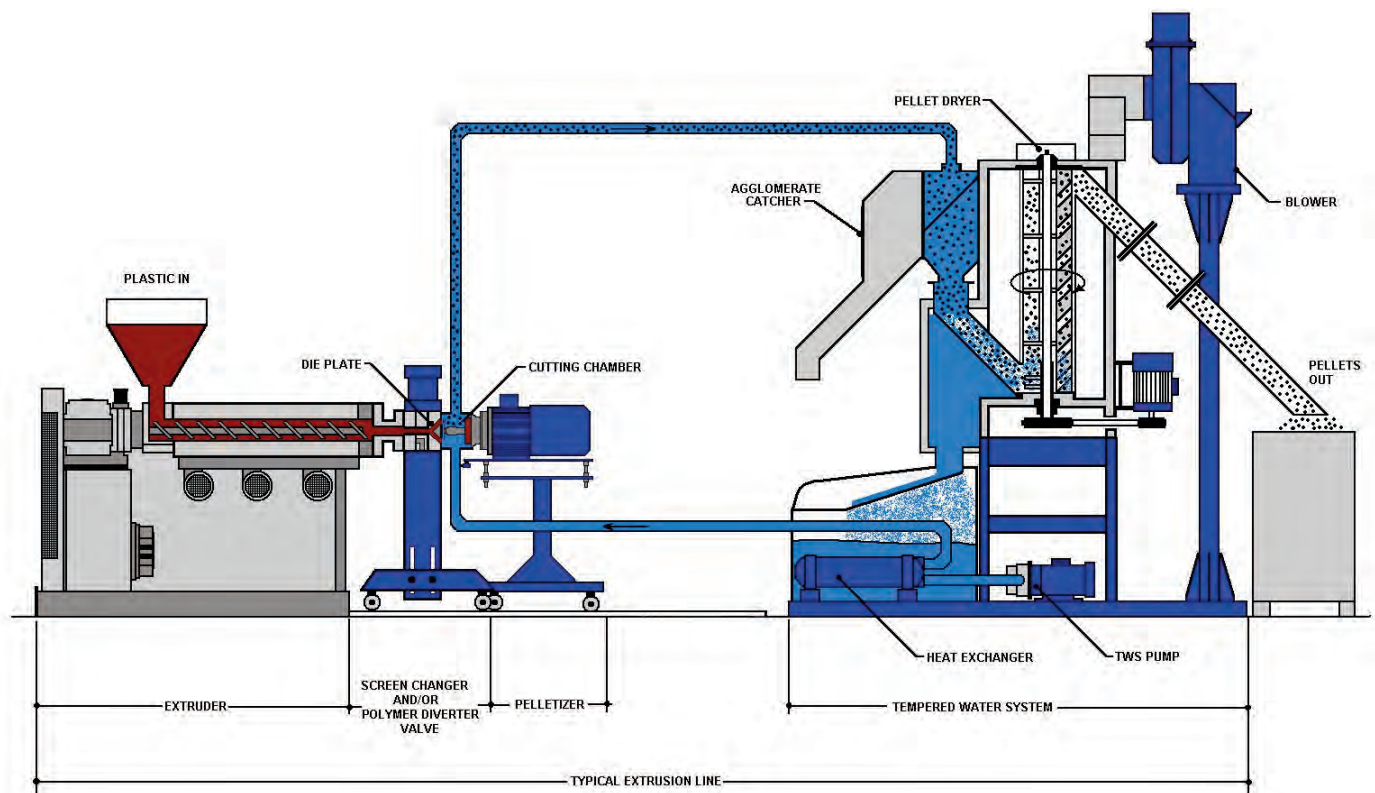

GALA PELLETIZING SYSTEMS

Gala is a worldwide leader in the production of underwater pelletizing systems for pellet rates up to 15.000 kg/h. Gala has established benchmarks in the development of standardized modular pelletizing systems which permit economical and technical solutions for a wide variety of applications, e.g.:

- Compounding
- Masterbatch Production
- Virgin Resin Production
- Engineering Resins
- Medical & Food Grade Polymers
- Plastics Recycling
- Micropellet Production
- Hot Melt Adhesives
- Thermoplastic Elastomers
- Wood Polymer Composites
- Research & Development

Gala pelletizing systems are used worldwide to process a wide variety of polymers. These applications include high additive content, high viscosity to very low viscosity materials.

The typical Gala pelletizing system consists of three main components that can be customized for each pelletizing situation:

1. Pelletizer and die plate
2. Tempered Water System (TWS) with Centrifugal Dryer
3. Electrical Control and Power System

The pelletizing system interfaces with the customer's extruder or melt pump.

The pelletizing process is performed in a closed loop system, and the pelletized product is conveyed by the process water from the cutting chamber into the centrifugal dryer.

During this process, the pelletized product has no contact with ambient air and there is no risk of gas, dust emission or contamination of the product. The process water remains in the closed loop tempered water system — another advantage which contributes to the environmental compatibility of this process.

LPU® LABORATORY PELLETIZING UNIT

LPU® LABORATORY PELLETIZING UNIT is designed for lab use or light production at pellet rates up to 100 kg/h.

The LPU® Laboratory Pelletizing Unit includes an underwater pelletizer, a tempered water system and a new and simple pellet dryer — all mounted on a single skid with swivel casters.

All necessary electrical controls are contained in a simple modular, free standing panel with a local touch screen for operator convenience.



BENEFITS:

- Easy to clean!
- Simple & easy to operate!
- Lightweight, portable!
- Designed to be affordable!
- Requires few replacement parts!

COMPACT LAB SYSTEM

Gala's **COMPACT LAB SYSTEM**, is used downstream of an extruder or gear pump. It is designed for use in laboratory settings and by compounders when pelletizing and drying samples of polyethelene, polypropylene, polystyrene, ABS, flexible PVC and other polymers at pellet rates up to 500 kg/h.



BENEFITS:

- Inexpensive
- Compact and portable
- Designed to simulate the function of a full production pelletizing system.

- ✓ Quality
- ✓ Innovation
- ✓ Commitment
- ✓ Service



GALA PELLETIZING SYSTEMS

The EDGE™ SYSTEM

The EDGE™ SYSTEM is designed to economically pelletize and dry thermoplastics — PE, PP, PS, Flex. PVC and more at pellet rates up to 1.000 kg/h.

BENEFITS:

- Simple and compact
- Engineered to include the fundamental operational and safety concepts of Gala's more complex underwater pelletizing systems
- Includes a fully functional PLC based control system with touch screen interface, an SLC pelletizer and a skid mounted Tempered Water System with dryer.



PELLETIZING SYSTEMS FOR GLASS FIBER COMPOUNDS

Glass fiber compounds have traditionally been produced by strand pelletizing; recent trend shows movement toward underwater pelletizing. Because of the highly abrasive characteristics of these polymers, special wear resistant coatings are used. The true challenge does not lie in the production of the pellets but in the downstream processing, and in particular the drying of the pellets.



Wear protected cutter hub

BENEFITS:

- Cutting the product in its molten state permits a good integration of the glass fiber within the pellet.
- Development of fine dust is very low
- Automatic start-up and minimum waste
- No broken strands and downtime due to extrusion process fluctuations
- Production at higher process water temperatures reduces cooling energy requirements.

The FLEXLINE PELLETIZING SYSTEM

The FLEXLINE PELLETIZING SYSTEM permits complex product changes within a matter of minutes, minimizing downtime.

BENEFITS:

- Quick start-up
- Repeatable results
- Minimum labor required
- Low capital expenditure
- Flexibility to process a wider range of formulations
- Wear resistant tooling
- Minimizes quality variations
- Reduced product loss
- Raw material savings



LOW WASTE CONTINUOUS PRODUCTION (LWCP) PELLETIZING SYSTEM

The LWCP System was designed to allow the user to operate the production line on a continuous basis and increase output without interruptions. The multidirectional polymer diverter valve allows for very fast changeover between two product flow directions or sequential operation of several pelletizers connected to one common polymer diverter valve. Interruptions are avoided, variation in pellet rates are possible and start-up waste is reduced to a minimum.

BENEFITS:

- Lower cost start-ups
- Less material waste
- Lower operating costs
- Fewer line shutdowns for maintenance



GALA DIRECT CRYSTALLIZATION PROCESS TECHNOLOGY

An exciting development for the industry and specifically for crystallizing polymers is the Direct Crystallization Process. This process avoids the use of expensive pre-crystallizers and crystallizers prior to taking the pellets into the SSP process or other downstream after-treatment processes.

The direct crystallization process offers two energy reducing elements. It retains sufficient heat in the pellets to cause the polymer to crystallize without any additional external heat required. It also allows the free flowing pellets to go directly into either packaging or downstream after-treatment processes, like the SSP process.

The Gala Crystalline Pellet Technology (CPT®) process complements this direct crystallization and is superior in method of operation. The Gala CPT® Process uses high velocity gas injection to increase the velocity of the water and pellet slurry and to create a water vapor mist that separates the pellets from the water. The vapor mist insulates the pellets from the cooling effect of the water and further enhances the internal heat to crystallize the pellets. Gas injection produces a much lower and safer process water temperature and flow rate. Typically the water temperature does not need to be above 70 degrees Celsius and the process water flow rate does not need to be increased above standard underwater pelletizing guidelines.

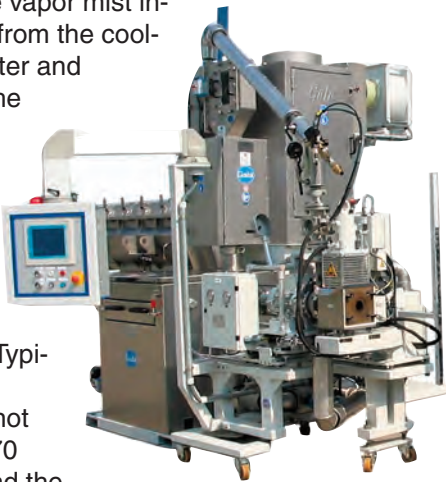

Gala CPT® Process System

BIOPOLYMERS

The industry is experiencing significant growth in the biopolymers sector. Gala has been working in this environmentally friendly field to offer innovative pelletizing and process solutions to allow resin producers and compounders to focus on their formulations and applications.

It has been more than ten years since Gala began producing quality biopolymer pellets for packaging and processing, and since then Gala pelletizing systems for biopolymer applications have been placed in a number of companies in Europe, North America and Asia. In addition to our basic efficient, economical pelletizing and drying process, Gala can provide an additional benefit to customers whose

processes include a crystallization step. Our progressive CPT® Process provides a direct crystallization method adding value to the producer's product and significantly reducing cost. The option to produce crystalline biopolymer pellets at water temperatures below T_g is easily possible with the Gala CPT® Process, as the pellets are already separated from the water at a very early state of transportation within the process water pipes.



PLA pellets cut with a Gala Underwater Pelletizer

Biopolymers are in a rapid state of end product application development and Gala's leadership in micropelletizing has proven to be very beneficial for these applications. Size reduction of newly developed materials can be a significant challenge for resin producers and compounders. Gala's dedicated micropelletizing efforts and its application development in this globally important field offers a great resource to any company working with such requirements. We encourage all our customers to tap into and to benefit from our expertise.

i-Heat™ PROCESS

Gala has extensive experience working with wood compounds. Gala's pelletizing process is extremely versatile and can process a broad range of base polymer grades. Other pelletizing methods suffer cutting problems when the percent of wood filler is reduced below a certain level, when a low viscosity polymer is required, or when the compound is sticky or tacky. The Gala pelletizing process can minimize or eliminate these issues.

A common concern during underwater pelletizing is the amount of water absorbed by the wood compound pellets which must later be removed for packaging or processing. Gala's new i-Heat™ Process maximizes the benefits of underwater pelletizing, greatly reducing the pellet exposure to process water and efficiently optimizing the internal heat energy of each pellet to help dissipate moisture. Contact Gala to discuss our efficient solutions for wood compound pellet production process.



PP Wood Fiber cut with a Gala Pelletizer



COMPONENTS OF THE PELLETIZING SYSTEMS

DIE PLATE

The die plate is the heart of the Gala underwater pelletizing system. All Gala dies are custom designed to fit each customer's specific polymer requirements. The material of construction and wear face material are determined by the specifications of the Customer's application. All die face surface materials provide maximum wear life before resurfacing is required.

Gala's standard electrically heated die is suitable for most applications; however, oil or steam heating can be utilized.

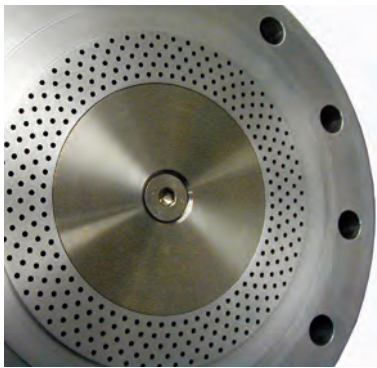

The dies are available in one-piece design or in our patented two-piece design. The advantage of the two-piece design is the center (Insert) of the die can be removed from the main



Model 6 Die Plate Insert

body for routine maintenance. Much research and development has been invested in our dies to ensure our customers have the most energy efficient, operator friendly pellet production system available.

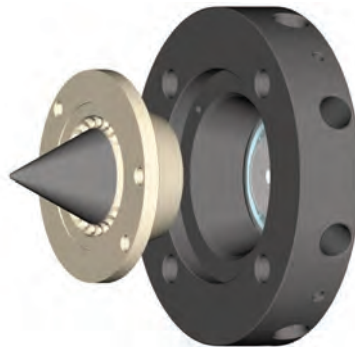

Two-piece Die Plate

MULTI-ZONE DIE PLATE HEATING CONCEPT

A significant advancement in Gala's underwater pelletizing technology is the multi-zone die plate heating concept which provides local heating when and where required for the application. This innovative



heating design is reactive and at the same time direct-acting to ensure that the required energy is delivered exactly where it is most needed. It is available for all pelletizer models and can be used for continuous production processes, with one piece die plates, as well as two piece design die plates, where frequent and quick changes are required.

CUTTER HUB

Gala's patented self-aligning cutter hub provides precise positioning between the die plate and pelletizer shaft, ensuring alignment of all cutter blades against the die face. This results in uniform pellet quality and reduced blade and die face wear.

BENEFITS:

- Lower force against the die plate
- Reduced die and blade wear
- Quick and efficient cutter hub / blade changes



Model 12 Cutter Hub

BENEFITS OF GALA DIE PLATES:

- Process-optimized flow channels
- Ideal melt distribution through radial arrangement of the holes
- Deflection free melt guidance free of dead spots
- Direct introduction of the melt into the cooling circuit
- Containment of the melt until the formation of pellets
- Optimum heat transfer from the heating medium to the flow channels
- Excellent heat insulation of the die plate
- Selection of a suitable cutting face coating for temperature sensitive polymers
- Selection of the suitable heating medium depending on throughput and polymer
- Reduction of wear by selecting the optimum cutting face coating (hard metal, Stellite) and using an offset arrangement of the outlet holes
- Blade grinding during pelletizing without stopping the line
- Cooling of the cutter blades in the water flow



CUTTER BLADES

D2 is the material of construction known as the benchmark of the industry. This material will usually get the job done at a low price. The primary element is 12% Chrome which gives the blade good toughness and rust resistance.

M-2 material is a member of the high speed family of tool steels. Under most circumstances, M-2 should last 1.5 times longer than D-2.

PM (Powdered Metal) has a 9% Vanadium content which gives it a huge advantage in both wear and toughness. Depending on conditions, this material should last 3x to 5x longer over D-2.

440A Stainless Steel (available on special request only) has an 18% Chrome content and is part of the stainless steel family of tool steels. This is the best tool steel offering for knives that are used in very corrosive conditions. This very special grade of stainless is able to be hardened to 54 / 56 HRC.

Specialty blades, such as half thick or half length, or various materials of construction, are available for special pelletizing applications.



CUTTING CHAMBER

The cutting chamber is the housing in which the pellets are actually cut. The pelletizer is coupled to the cutting chamber, which places the cutter

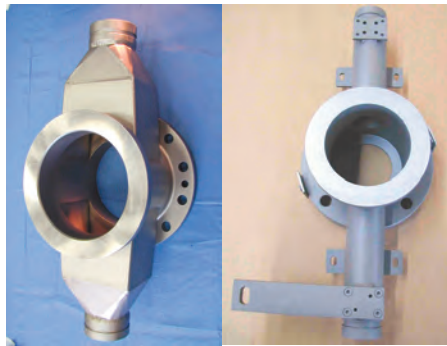

blades inside the cutting chamber (often referred to as the water box), where the blades will contact the die face. As the process water enters the inlet of the cutting chamber, molten polymer is simultaneously cut into pellets by the rotating cutter blades. At this point the pellets begin to harden and are carried by the process water from the cutting chamber to the dewatering system. From this system or centrifugal dryer, the pellets are ready for downstream processing or packaging.

Note: 180 degree rotation is possible, meaning double the life of the water box.

Abrasive resistant coatings are utilized, based on application requirements.

DIE PLATE GRINDING TOOL

Gala's die grinding tool gives you the option of grinding the die plate without removing it by simply threading the tool onto the cutter hub holder in place of the cutter hub.

This unique tool is an effective method of removing small irregularities and grooves that can adversely affect pellet quality.

High quality design and diamond materials of construction provide the user with a superior and affordable die grinding tool.



FLOW GUIDE

Gala provides a number of innovative tools for the operator of a Gala Underwater Pelletizer. These tools are designed to allow the successful performance of specific tasks.

The flow guide provides optimization of the process water flow:

- Patented flow guide
- Water flow direct to the die plate
- Avoidance of agglomerates
- Reduction of the water flow rate
- Reduction of the pellet moisture
- Smaller dryer possible (less dewatering required)

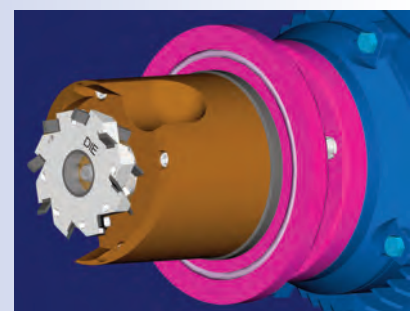

COMPONENTS OF THE PELLETIZING SYSTEMS

POLYMER DIVERTER VALVE (PoDV)

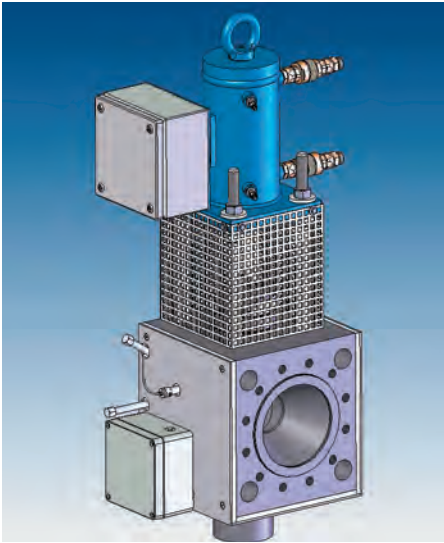

The polymer diverter valve is used to direct the polymer melt from the pump or extruder to the floor, to the side, or directly into the die plate.

This is an indispensable function during start-up for difficult products that are sensitive to temperature fluctuation. In underwater pelletizing, an optimized volume flow per die hole must be ensured right from the start. Most of the upstream equipment responds rather slowly, e.g. ramping up of the extruder. The polymer diverter permits a controlled start-up of these upstream components until the required throughput has been attained and allows a visual control of the compounding process by the operator. The option of diverting the melt is often used for online material or color changes.

The polymer diverter valve consists of a heated housing with an integrated bolt that can be moved hydraulically. This bolt allows the melt flow to be diverted from the start-up position to production position, i.e. toward the die plate, within one second. In many cases, the inlet channel of the polymer diverter valve is adapted directly to the extruder outlet, screen changer or to the melt pump, eliminating the

need for an additional intermediate adapter. The integration of a nose cone on the die plate at the outlet of the polymer diverter valve reduces the length of the flow channel and the volume of melt dead area before the die plate. This reduction of dead area prevents excessive melt flow through the die plate after extrusion has stopped so the system can be restarted with a generally clean die plate. This helps prevent the risk of polymer wrapping and increased agglomerate formation during start-up. A mobile support stand simplifies the removal or backing away of the polymer diverter valve pulling from the extruder screw.

BIDIRECTIONAL POLYMER DIVERTER VALVE (BiPoDV)

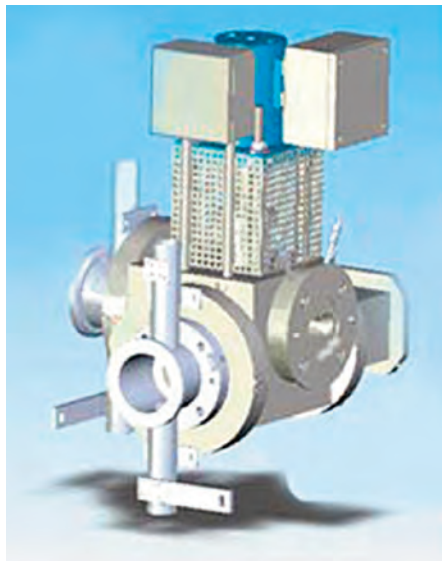

With the bidirectional polymer diverter valve (Model BiPoDV), the melt is diverted sequentially into different directions. This means that, depending on the requirements of the job, the machine operator can work with two pelletizing heads that can be individually configured. The operator can prepare the machine for the next task and assemble, heat and tighten the ideal pelletizing tools under full production conditions. All connecting channels are freely accessible so the most recently used channels can be thoroughly cleaned. For product change, the polymer diverter valve housing is rotated and lifted into the new production position so melt flow

is directed to the new fully prepared tool. The change of melt direction for the next production job can be readied in very little time and without tools.

MULTIDIRECTIONAL POLYMER DIVERTER VALVE (MdPoDV)

With the multidirectional polymer diverter valve (Gala Model MdPoDV), the melt is diverted sequentially into different directions during production. The MdPoDV is designed to allow a continuous operation of the produc-



tion machine and to increase output without interruptions from a defined minimum throughput up to the maximum line throughput. The machine does not have to be stopped and no throughput related modifications are required, so only minimum start-up waste is generated. At least one additional diverting operation is integrated, in addition to diverting to the floor or production position, allowing faster change over between two product flow directions or the sequential operation of multiple pelletizers connected to the same diverter valve.



TECHNICAL ASSISTANCE

Gala's support of our Customers is paramount in every aspect of our business, and has earned us the reputation for reliable, consistent, prompt and dependable service. Our Sales and Service Staff are the most experienced in the industry and pride themselves in providing excellent service.

Every customer call is handled with priority. In the event an issue cannot be resolved by phone, the customer then has the option to request on-site technical assistance.

The mobile phone number of every technician is published on our website so they are available 24 hours a day. When a service call comes to our switchboard after business hours, the call is taken by a technician on call.

*Gala's Technical Support
is Simply The Best
in the Industry!*

TECHNICAL CENTERS

Gala's technical centers are available to customers who wish to evaluate the suitability of a Gala system for purchase, for assistance in product development, R&D, or for product market sampling.



Technical Center at Gala GmbH, Xanten, Germany

INFORMATION NEEDED TO REQUEST A QUOTATION

Company Name: _____

Department: _____

Name: _____

Title: _____

Address _____

City: _____

Country: _____

PostalCode: _____

Telephone: _____

Fax: _____

E-mail: _____

Website: _____

PRODUCT(S): _____

Fillers & Percent: _____

Required kg/h: _____

Pellet Diameter (mm): _____

Viscosity of Material (Pas): _____

Residual Pellet Humidity Percentage: _____

Power Supply: _____ Volts _____ Hz

Operation Time: _____ hrs. / day

Do you already use pelletizing systems or dryers? If yes, which ones and manufacturer?

Upstream Equipment: _____

Comments: _____





Gala Industries, Inc.

181 Pauley Street, Eagle Rock, VA 24085 USA

Tel: 540 884 2589 • Fax: 540 884 2310

www.gala-industries.com

Gala Kunststoff- und Kautschukmaschinen GmbH

Bruchweg 28-30, 46509 Xanten, Germany

Tel: +49 (0) 2801 9800 • Fax: +49 (0) 2801 98010

www.gala-europe.de

Gala Industries Asia Ltd.

Amata City Ind. Est., 9/34 Moo 4, T.Mabyangporn

A. Pluakdeang, Rayong 21140, Thailand

Tel: +66 38 956 245 • Fax: +66 38 956 246

www.gala-industries.com

Gala technology is protected, in whole or in part, by one or more issued U.S. and foreign patents, with other domestic and foreign patents pending. Patents include US Patent Nos. 5,265,347; 5,403,176; 5,624,688; 5,638,606; 6,138,375; 6,237,244; 6,332,765; 6,551,087; 6,739,457; 6,793,473; 6,807,748; 6,824,371; 6,925,741; 7,024,794; 7,033,152; 7,157,032; 7,171,762; 7,172,397; 7,267,540; 7,318,719; 7,393,484; 7,402,034; 7,421,802; 7,524,179; and related foreign patents; All logos, trademarks, and service marks (hereafter referred to as "Trademarks") displayed herein whether or not appearing in large print or with or without the trademark symbol are registered and unregistered Trademarks of Gala or of third parties. Gala Trademarks are protected by one or more registered U.S. and foreign trademarks, with other domestic and foreign trademarks pending. All original works of authorship displayed herein is protected under U.S. and other copyright laws. Gala technology may also be protected as trade secrets, mask works or other proprietary rights.